

Creda

HEATING

INSTRUCTION MANUAL

Installation and Operating



Creda CTR Towel Rail

Models: CTR7W / CTR7C / CTR10W / CTR10C / CTR12W / CTR12C

These instructions should be read carefully and retained for future use. Note also the information presented on the appliance.



IMPORTANT

THESE INSTRUCTIONS SHOULD BE READ CAREFULLY AND RETAINED FOR FUTURE REFERENCE. Note also the information presented on the appliance

IMPORTANT SAFETY ADVICE

When using electrical appliances, basic precautions should always be followed to reduce the risk of fire, electrical shock, and injury to persons, including the following:

IMPORTANT: The wall bracket supplied with the appliance must be used.

WARNING - THE SURFACE OF THIS RADIATOR CAN BE HOT.

In order to be effective the towel rail will get hot, however momentary contact with any part of it should not cause injury.

WARNING - In order to avoid a hazard for very young children, this appliance should be installed so that the lowest heated rail is at least 600mm above the floor.

WARNING - This appliance must not be located immediately above or below a fixed socket outlet or connection box.

IMPORTANT - If the towel rail is to be installed in a place used by the public, a warning notice should be placed adjacent to the rail advising that the surface can be hot.

CAUTION - This appliance can be used by children aged from 8 years and above and persons with reduced physical, sensory or mental capabilities or lack of experience and knowledge if they have been given supervision or instruction concerning use of the appliance in a safe way and understand the hazards involved. Children shall not play with the appliance. Cleaning and user maintenance shall not be made by children without supervision.

Children of less than 3 years should be kept away unless continuously supervised. Children aged from 3 years and less than 8 years shall only switch on/off the appliance provided that it has been placed or installed in its intended normal operating position and they have been given supervision or instruction concerning the use of the appliance in a safe way and understand the hazards involved. Children aged from 3 years and less than 8 years shall not plug in, regulate and clean the appliance or perform user maintenance.

CAUTION - This appliance is not intended for use by children or other persons without assistance or supervision if their physical, sensory or mental capabilities prevent them from using it safely. Children should be supervised to ensure that they do not play with the appliance.

The towel rail is to be installed so that switches and other controls cannot be touched by a person in the bath or shower.

Precautions should be taken to ensure that prolonged contact with the towel rail cannot occur. Particular care should be taken in confined areas where accidental prolonged contact with the rail could be more likely to occur.

IMPORTANT - If the supply cord is damaged it must be replaced by the manufacturer or service agent or a similarly qualified person in order to avoid a hazard.

This appliance should only be used to dry fabrics washed in water using commonly available detergents.

A means for disconnection must be incorporated in the fixed wiring in accordance with the wiring rules.

The device must be fixed on its supports; the use of adhesives to fix the supports or the device is prohibited.

WARNING - The towel rail is a sealed unit and is filled and sealed under controlled conditions. Under no circumstances should the seal of the unit be compromised.

This heater is filled with a precise amount of special fluid. Repairs requiring the opening of the tank should only be carried out by the manufacturer or its after-sales service, which should be contacted in the event of an fluid leak. When the heater is discarded, follow regulations regarding fluid disposal.

If the supply cord is damaged it must be replaced by the manufacturer or service agent or a similarly qualified person in order to avoid a hazard.

Electrical connection

WARNING: THIS APPLIANCE MUST BE EARTHED

The electrical installation must be carried out by a competent electrician, and be in strict accordance with the current IEEE Regulations for Electrical Equipment in Buildings. This heater must be used only on an alternating current (AC) supply and the voltage marked on the heater must correspond to the supply voltage. The mains lead specification for the panel heaters are H05VV-F, size 3 x 1.0mm². The wires in this mains lead are coloured in accordance with the following code:

GREEN AND YELLOW: EARTH

BLUE: NEUTRAL

BROWN: LIVE

The heater is fitted with a length of flexible cable type and without any plug for connection to the fixed wiring of the premises through a suitable connection box positioned adjacent to the heater. A means for disconnection must be incorporated in the fixed wiring of the premises in accordance with the wiring rules. The supply circuit to the heater must incorporate a double pole isolating switch having a contact separation of at least 3mm.

Supplementary Earth Bonding

Should Equipotential Earth Bonding be required the earthing conductor in the supply cord is deemed to provide the supplementary bonding connection (see Regulation 544.2.5, 17th Edition I.E.E. Wiring Regulations).

Energy Related Product Directive

Product information according to Ecodesign Regulation (EU) 2015/1188

Type of heat output/ room temperature control	
Electronic room temperature control plus week timer	Yes
With open window detection	Yes

Model Identifier(s):		CTR7W	CTR7C	CTR10W	CTR10C	CTR12W	CTR12C	Unit
Nominal heat output	P _{nom}	0.12	0.08	0.175	0.12	0.25	0.175	kW
Minimum heat output (indicative)	P _{min}	N/A						kW
Maximum continuous heat output	P _{max,c}	0.12	0.08	0.175	0.12	0.25	0.175	kW
Auxiliary electricity Consumption								
At nominal heat output	e _{lmax}	0.00						kW
At minimum heat output	e _{lmin}	0.00						kW
In standby mode	e _{lSB}	<0.001						kW
Open window detection		Yes						

Contact details:

Glen Dimplex Heating and Ventilation

Millbrook House, Grange Drive, Hedge End, Southampton, SO30 2DF

Tel: 0344 879 3588

This product meets the Ecodesign requirements for an electric local space heater.
Commission Regulation (EU) 2015/1188.

Dimensions

Model(s)	Watt (W)	H	W	H1	W1
CTR7W	120	692	500	500	360
CTR7C	80	692	500	500	360
CTR10W	175	992	500	800	360
CTR10C	120	992	500	800	360
CTR12W	250	1192	500	1000	360
CTR12C	175	1192	500	1000	360

See Fig.1. All dimensions are in mm.

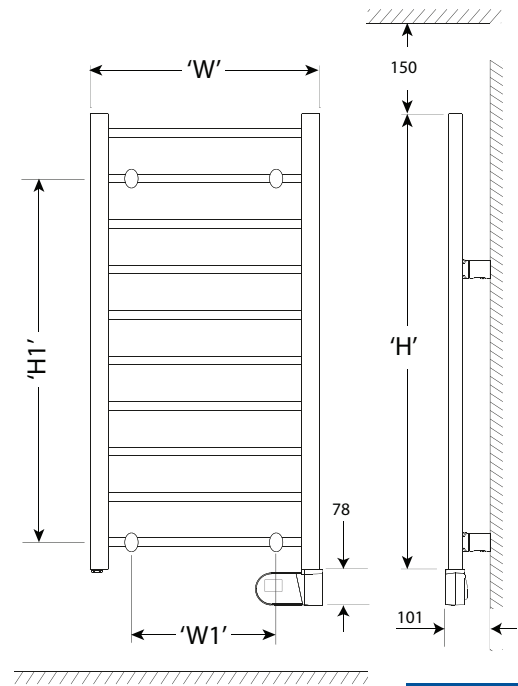

Fig. 1

General

The CTR towel rail is designed to provide an all year round service for airing towels and articles of clothing. It is not intended to provide a sole heating service, but the larger model will take the chill off an average size bathroom, lavatory or en suite.

Covering the rail may affect the room temperature sensor and therefore impact the room temperature control accuracy.

Heat will be distributed along each of the rails.

Some variation in the temperature across the surface of the rail is normal. When the appliance is covered the heating pattern of the rails may alter, and generally temperatures at the upper part of that rail will rise.

No routine maintenance is necessary apart from occasional cleaning.

All models are splash proof to IPX5 standard.

Drying and Airing Towels

It is recommended that for efficient drying, no more than two layers of towels or similar fabric should be draped over the rail. Items should be placed evenly over the whole surface of the rail where possible.

It is not advisable to leave very damp towels or clothes on the towel rail when not in use, as this may in time, affect the paint finish.

The rail, although hot to the touch is not hot enough to scorch or burn fabrics. However, soap and detergents remaining in articles after washing can cause discolouration. Therefore care should be taken to thoroughly rinse articles before airing.

Electrical

WARNING: THIS APPLIANCE MUST BE EARTHED.

The electrical installation of this towel rail must be carried out by a competent electrician in accordance with the current I.E.T Regulations for Electrical Equipment. The towel rail is suitable for use on an A.C.~ electrical supply. Before installation check that the supply voltage corresponds with that marked on the rail.

IMPORTANT - The wires in the mains lead are coloured in accordance with the following code:
GREEN and YELLOW - EARTH
BLUE - NEUTRAL
BROWN - LIVE

This appliance must only be used on A.C. mains supply of 230/240 Volts~.
In accordance with wiring rules a suitable means for disconnection must be incorporated in the fixed wiring.

Wall Mounting

IMPORTANT - The wall bracket kit supplied with the rail must be used and the rail must be installed in the correct orientation. The fixings should be used to secure the bracket to the particular wall on which the heater will be installed. The heater should be positioned observing the minimum clearances stated around the heater - see Fig. 1.

The wall mounting accessory pack contains - see Fig.2:

- (A) 4 Mounting collars, (B) 4 Rail seats,
- (C) 4 Inner wall bracket sleeve, (D) 4 Outer wall bracket sleeve,
- (E) 4 Position locking screws, (F) 4 Wall plugs, (G) 4 Wall mounting screws,

Installation

If fitted in a room containing a bath or shower, to comply with the current I.E.T. Regulations, a cable outlet will be necessary with the supply to the heater controlled by a double-pole switch having a contact separation of 3mm in each pole. The body of the switch should be situated as to be normally inaccessible to a person using a bath or shower. Alternatively the switch can be located outside of the bathroom.

IMPORTANT - Protect the electrical connection whilst handling the towel rail.

The towel rail must be permanently fixed to the wall using the wall brackets supplied. The rail must be mounted vertically as shown observing the minimum clearances stated.

WARNING: The towel rail is heavy. Do not remove without seeking specialist advice.

Installation Procedure

1. Mark suitable mounting hole positions for the fixing brackets (ensuring they are horizontal) - see Fig. 1 (Dim W1 & H1), ensure to allow enough room above and below to maintain the minimum clearance stated in Fig. 1.
2. Drill and plug (F) the wall to suit. Fix the outer wall bracket sleeve (D) to the wall using the screws provided (G). Ensure to align the bracket so that the fixing hole is accessible once the towel rail is fitted - see Fig. 3.

Note: We recommend that the fixing hole is positioned horizontally, towards the side of the towel rail. This will allow easy access with a screw driver when fixing the rail in its final position.

3. Carefully assemble the four mounting collars (A) and rail seats (B) to the towel rail and secure in the positions by inserting and turning the inner bracket sleeve (C) through 90 degrees as shown in Fig. 4. The brackets should be placed on the bottom and second from top rails and separated by a distance of 360mm. Ensure the inner bracket sleeves are facing directly backwards.
4. Lift the towel rail complete with the bracket assemblies and align with the outer bracket sleeves which were previously fixed to the wall. Insert the inner sleeve brackets into the outer sleeve brackets and fix in place using the position locking screws (E). The rail is then locked in place by rotating the pins a quarter turn - see Fig. 5.

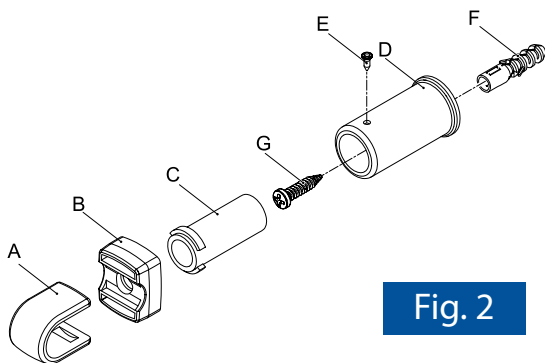

Fig. 2

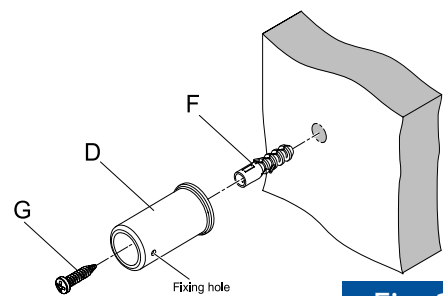

Fig. 3

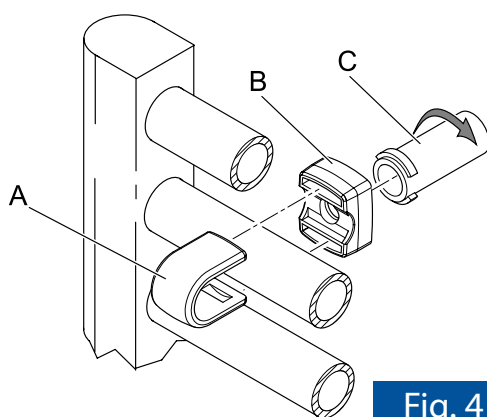

Fig. 4

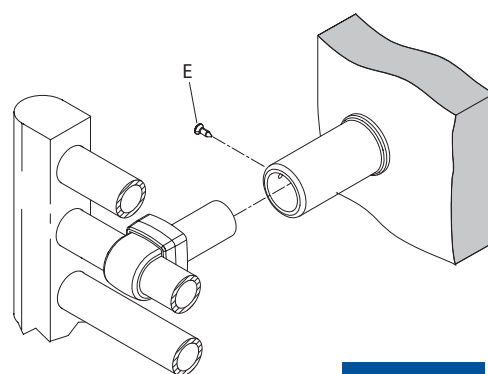

Fig. 5



WARNING:
This product is heavy and care should be taken in installation.



NOTE:
Remove protective film from the user interface before operating the product.

Operation

WARNING: FAILURE TO FOLLOW THESE OPERATING INSTRUCTIONS MAY RESULT IN INJURY AND/OR DAMAGE.

The controls are located at the base of the heater consisting of a display screen and six buttons.

- 1 Daily Preheat Period 1 indicator
- 2 Daily Preheat Period 2 indicator
- 3 Usage indicator
- 4 Display Screen
- 5 'Mode' Button
- 6 'Daily Preheat' Button
- 7 'On/Off' Button
- 8 'Boost' Button
- 9 'Up and Down' Buttons

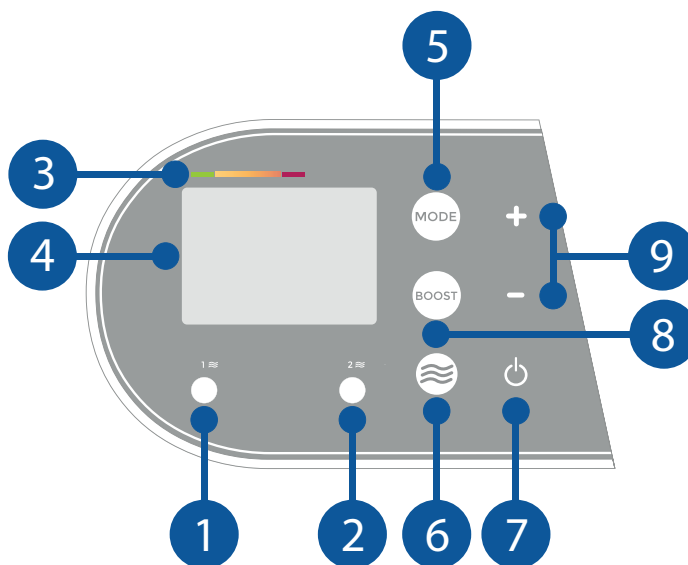

The heater controls can be easily adjusted by using the six buttons on the User Interface.

The Home Screen (4) shows the options available at each stage of adjustment. Here the current target room temperature is displayed along with the mode of operation.

The currently active mode of operation is displayed at the bottom of the screen (see F and G). See 'Modes of Operation' section for further information.

- A Energy Consumption Indicator
- B Open Window
- C Heating indicator
- D Setting value
- E Setpoint / menu option
- F Timer status
- G Mode of operation

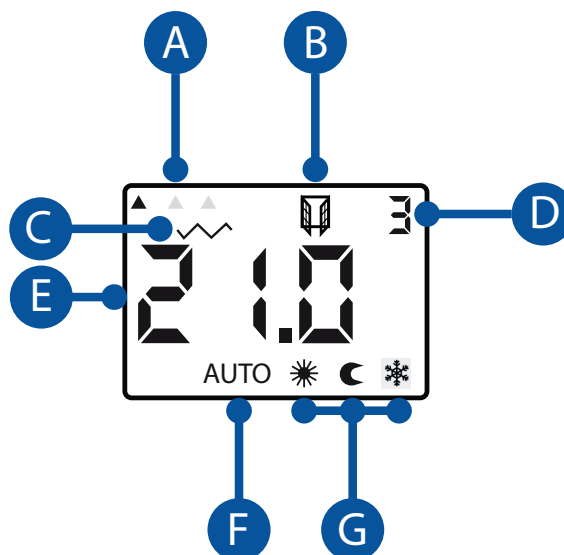

When the controller buttons have not been pressed for a long period of time, the backlight will turn off and the time will be displayed. The heater is still on and active in whatever Mode it was set to.

The Mode button (5) is used to enter sub menus, confirm action and save settings.

The Daily Preheat button (6) is used to configure the Daily preheat function. The daily preheat indicators (1 & 2) will be illuminated to indicate that period has been saved. See "Daily Preheat" for further information on this feature.

The on/off button (7) is used to turn the product on or off. When the product is turned off, '---' is displayed on the home screen. When the product is on, the active setpoint and mode of operation is displayed. The device keeps the settings in memory, even in the event of a power outage.

The Boost button (8) activates and deactivates the boost function. See 'Boost' section for further information.

The Up and Down buttons (9) are used to navigate through the menus and adjust the required room temperature on the main screen.

The heating indicator (C) tells you when your device is heating up. When the desired temperature is stabilized, it turns on and off according to heating needs.

The Energy Consumption Indicator (3) allows you to optimize the comfort temperature setting. Depending on its position, the cursor (A) alerts the user to whether or not the setting is economical. If the cursor is at the green symbol, the set temperature is less than or equal to the recommended temperature of 19°C.

The cursor is displayed when the setpoint is being modified.

This indicator makes it possible to control but also adjust the desired temperature according to its impact on consumption.



NOTE:

Your heater may produce some noise during operation. This noise is caused by the expansion and contraction of the element as it changes temperature, and is normal for this type of product. Whilst the noise produced is usually very quiet, certain environmental factors can make it more noticeable, such as hard flooring or minimal furnishings. If you believe that the expansion noise is excessive, please contact us.



NOTE:

Should the heater fail to operate, this may be caused by the room temperature being higher than the thermostat setting.

First Time Power-On

A setup wizard will display when the product is powered on for the first time, or the product as been powered off for an extended period. This process configures the time and date.

Step 1: Set the hour:

The first two digits will flash.

Modify the hour to the required value using the increase and decrease buttons.

Press mode to save the hour value.

NOTE: this product uses a 24hr time format.

Step 2: Set the minutes:

The last two digits will flash.

Modify the minute to the required value using the increase and decrease buttons.

Press mode to save the minute value.

Step 3: Set the day of the week:

"DAY" will be displayed on the screen followed by a day value.

Modify the value to represent the day of the week using the increase and decrease buttons.

- 1: Monday
- 2: Tuesday
- 3: Wednesday
- 4: Thursday
- 5: Friday
- 6: Saturday
- 7: Sunday

Press mode to save the day value.

The controller will then take the user to the Home Screen with continuous comfort mode active.

Modes of Operation





The controller has two principle operating modes, Continuous Heat mode and Timer mode, to offer flexibility to the user.

Continuous Heat mode is a continuous operating mode that will allow the user to set and maintain a constant room temperature.

Timer Mode will follow a time and temperature profile.

Repeatedly press the mode button to cycle through the available modes of operation.

The following modes are available. For further information on the timer modes, refer to the relevant section of this document.

Mode	Description	Symbol
COMFORT	Maintain the desired room temperature	
ECO	Maintain the room temperature at 3.5C lower than desired Comfort temperature point (this can be adjusted)	
FROST PROTECT	Keep the room at frost free temperature	
COMFORT (Timer off)	Maintain the desired room temperature	AUTO 
TIMER	Follow predefined or custom program	P



NOTE:

In the event of a short absence (more than 2 hours), it is recommended, for maximum savings, to use the ECO mode. It causes a lowering of the room temperature by approximately 3.5°C compared to the set temperature.



NOTE:

For maximum savings, in the event of a long absence (more than 24 hours), use FROST PROTECT mode. It helps maintain the room temperature at around 7°C.

Temperature Adjustment

The heater is fitted with an adjustable thermostat enabling the room temperature to be controlled. The minimum room temperature is 7°C. The maximum temperature is set to 28°C. A temperature of 21°C is a common comfortable room temperature.

Two adjustable setpoint temperatures can be configured.



Comfort temperature:

The Comfort temperature will be maintained when this symbol is displayed.

This temperature is maintained while the product is in continuous comfort mode or during timer on periods.

The setpoint temperature can be adjusted by pressing the up and down buttons while the Comfort symbol is displayed. It may be set to a value between 7°C and 28°C.



NOTE:

If the product is being used only to warm towels, rather than heat the room, it is recommended that a high Comfort temperature is set.



Eco temperature:

The Eco temperature will be maintained when this symbol is displayed.

This temperature is maintained while the product is in continuous Eco mode or during timer off periods. It is recommended to have this at a lower temperature than the Comfort temperature.

To modify the eco temperature, switch the product into Eco mode and hold the mode buttons for 3 seconds, until the eco temperature flashes.

Press the up or down button to modify and then press the Mode button to save the new temperature.



Frost Protect temperature:

The Frost Protect temperature will be maintained when this symbol is displayed.

This temperature is fixed at 7°C and cannot be modified.



NOTE:

To stabilize the temperature at the desired value, close the room doors.

The CTR towel rail is designed to provide an all year round service for airing towels and articles of clothing. It is not intended to provide a sole heating service, but the larger model will take the chill off an average size bathroom, lavatory or en suite.

Timer Mode

Timer Modes offer the most efficient mode of operation for a predictable heat demand.

The product has predefined profiles (Pr1 - Pr3) that cannot be modified and additional profiles (Pr4 - Pr6) that can be customised.

For each day of the week, the preferred profile can be selected. See 'Selecting Daily Profile'.

The predefined profiles are configured as follows:

- Pr1: 05:00-09:00 & 17:00-23:00
- Pr2: 05:00-09:00 & 12:00-14:00 & 17:00-23:00
- Pr3: 05:00-23:00

Each customised profile may consist of up to 3 definable 'Heating On' time periods. See 'Modifying a timer profile'.

When the heater is in a timer profile and trying to achieve or maintain a room temperature, the comfort symbol will be displayed, otherwise, the eco symbol will be displayed.

It is possible to change the Target Temperature of a 'Heating On' period when that period is active. This will permanently adjust the Target Temperature during the 'Heating On' time periods and Continuous Comfort mode.

Activating Timer Mode

Press and hold the Boost and Preheat buttons for 3 seconds to enter the timer settings.

To activate timer mode, press the up or down buttons until ON is displayed, then press the mode button to save this setting.

To deactivate timer mode, and operate the product in a continuous heat mode, press the up or down arrow until OFF is displayed, then press the mode button to save this setting.

After saving the required setting, press the up or down buttons until EXIT is displayed. Press the mode button to return to the homescreen.



NOTE:

The time and day must be set before activating "Comfort (Timer Off)" and "Timer" modes.

Selecting Daily Profile

A different profile can be selected for each day of the week.

The days of the week are represented by number 1 to 7.

- 1: Monday
- 2: Tuesday
- 3: Wednesday
- 4: Thursday
- 5: Friday
- 6: Saturday
- 7: Sunday

To select the required profile for each day of the week, follow the following steps:

Press and hold the Boost and Preheat buttons for 3 seconds to enter the timer settings.

The screen displays either ON or OFF. Using the up or down button, set to the ON position. Press the mode button to turn on the timer and progress to the next step.

If the time and day has not been configured, the screen will prompt for the settings to be configured. See "setting time and day" for further information.

'Pr' will be displayed on the screen. Press the mode button to enter this setting.

The first two digits represent the day of the week and the last two digits represent the timer profile (Pr1 - Pr6).

Press the up or down buttons to select the required profile for that day. Press the mode button to save the settings for that day and move to the next day.

Repeat this process to select the required profile for each day of the week.

When the settings are saved for day 7, 'Pr' will be displayed. Press the up or down buttons until EXIT is displayed. Press the mode button to return to the homescreen.

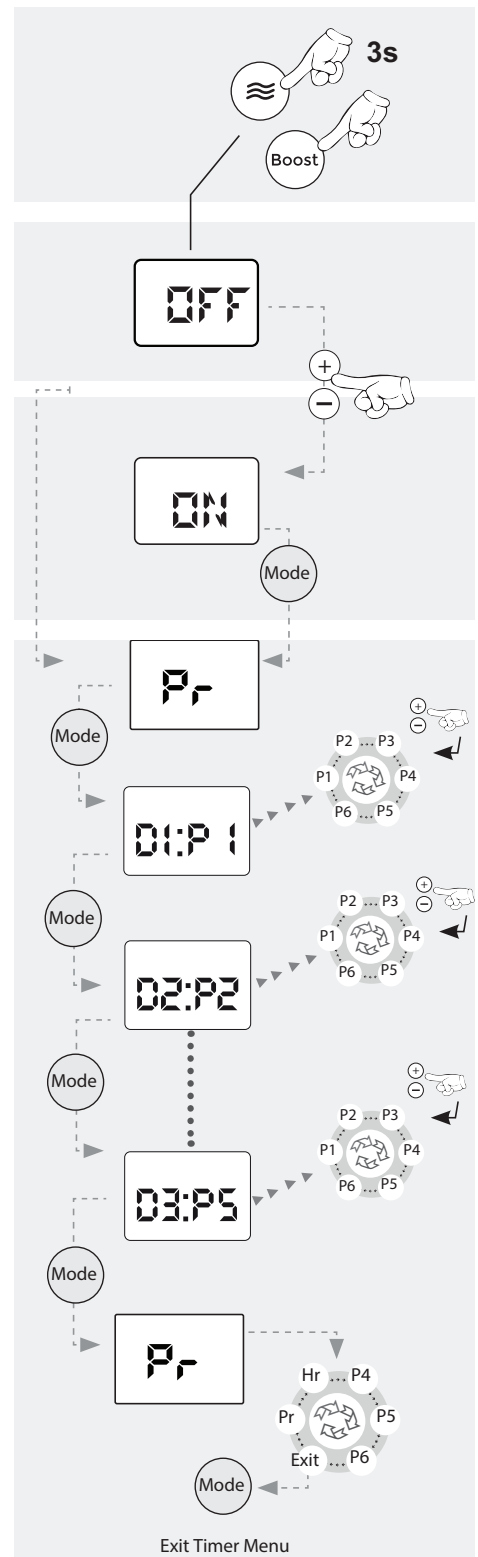

NOTE:

Once modified a Timer Mode must be selected if you want to begin using it.



NOTE:

Profiles P4-P6 will operate in Eco all day, by default. See 'Modifying a Timer Profile' to customise to your requirements.

Modifying a Timer Profile

Profiles Pr4 - Pr6 can be customised. You can therefore define your own 'Heating On' periods to maintain the comfort temperature. Outside of the defined periods, the eco temperature will be maintained.

Each profile consists of a 24-Hour period, starting and finishing at midnight and has 3 definable 'Heating On' periods.

By default, the profiles P4-P6 do not have defined period. If they are selected, without modifying as shown below, they will maintain the ECO temperature.

To modify the profiles, follow the following steps:

Press the Preheat and Boost buttons simultaneously for 3 seconds.

The screen displays either ON or OFF. Using the up or down button, set to the ON position. Press the mode button to turn on the timer and progress to the next step.

The screen displays "Pr".

Press the up or down button to choose one of the "P4/P5/P6" programs in the menu.

Press the mode button to begin customising the profile.

Continue to the next page for the remaining steps.

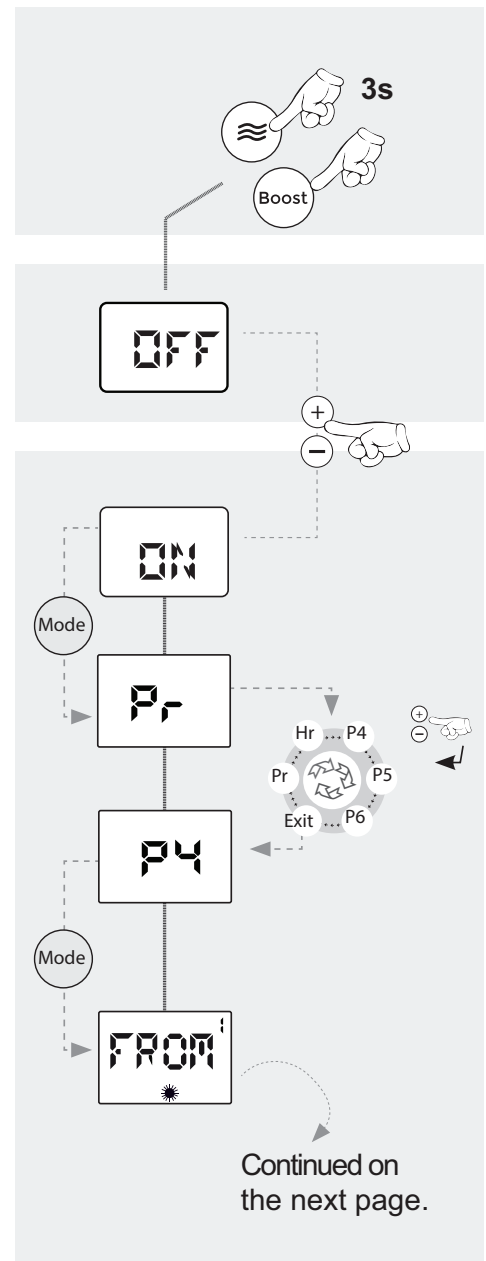

The following example demonstrates how to configure profile P4. The same process can be used to configure profiles P5 and P6 to the desired settings, if required.

In this example, the comfort temperature is required at the following times:

“Heating On” period 1: From 0600 to 0900

“Heating On” period 2: From 1100 to 1400

“Heating On” period 3: From 1800 to 2200

The period (1-3) currently being configured is displayed in the top right corner of the screen.

It is not necessary to configure all of the periods, if they are not required. If a period is not required, select “- - H” as the FROM value and this period will not operate.

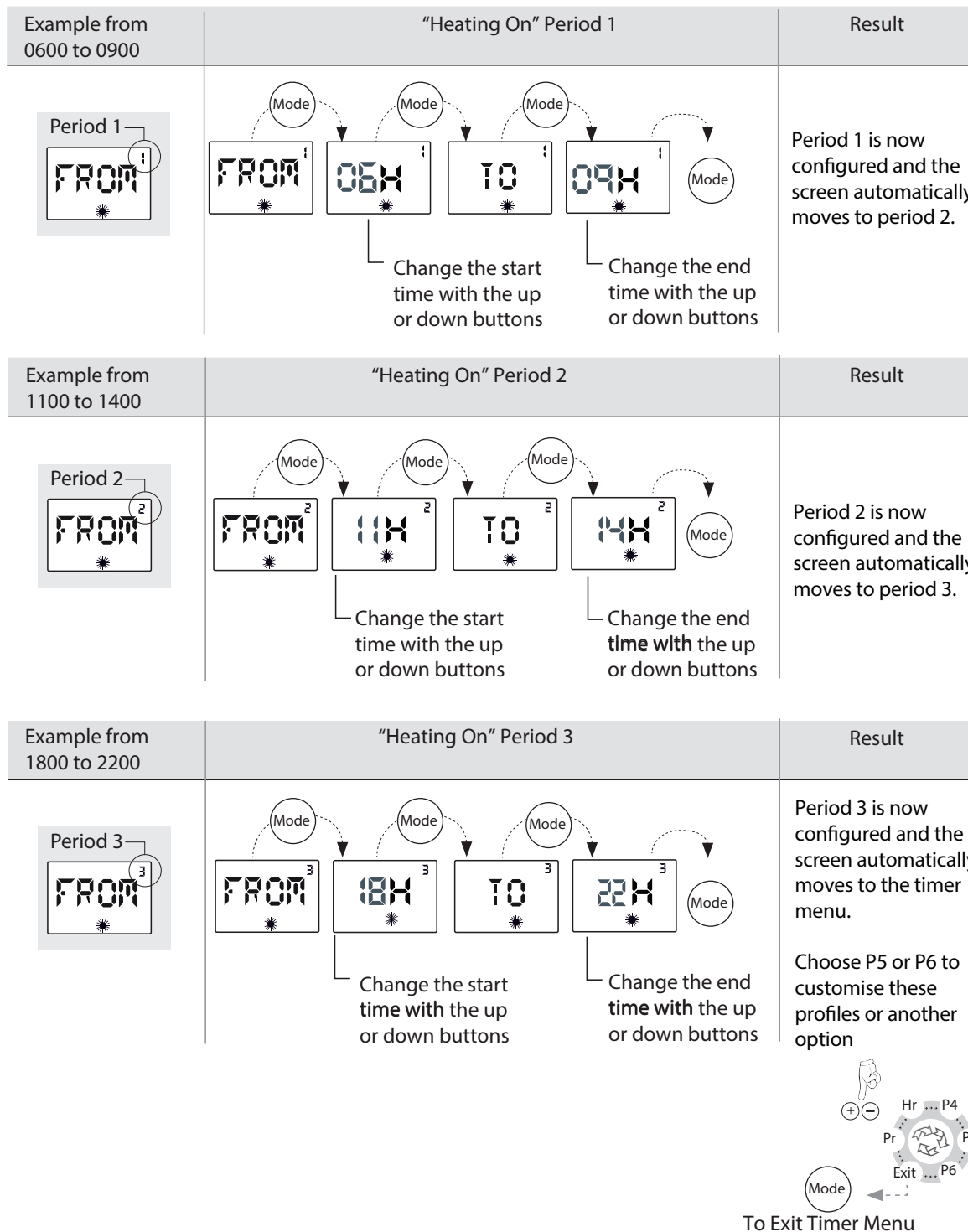

Setting the Time and Day

To set the time and day, follow the following steps:

Press the Preheat and Boost buttons simultaneously for 3 seconds.

The screen displays either ON or OFF. Using the up or down button, set to the ON position. Press the mode button to turn on the timer and progress to the next step.

The screen displays "Pr".

Press the up or down button to choose one of the "Hr" and press the mode button to enter.

The first two digits will flash. Using the up or down button, set the hour value. Press the mode button to save the hour value.

The last two digits will flash. Using the up or down button, set the minute value. Press the mode button to save the minute value.

"DAY" will be displayed on the screen, followed by a flashing number. Using the up or down button, choose the number which represents the day of the week. Press the mode button to save the day value.

- 1: Monday
- 2: Tuesday
- 3: Wednesday
- 4: Thursday
- 5: Friday
- 6: Saturday
- 7: Sunday

Pr' will be displayed on the screen. Press the up or down buttons until EXIT is displayed. Press the mode button to return to the homescreen.



NOTE:

In the event of a power outage lasting more than 30 minutes, the time and day will need to be reset. If the time and day have been lost, "00:00" will be displayed on the screen, with the first two digits flashing, to indicate that the time and day must be configured.

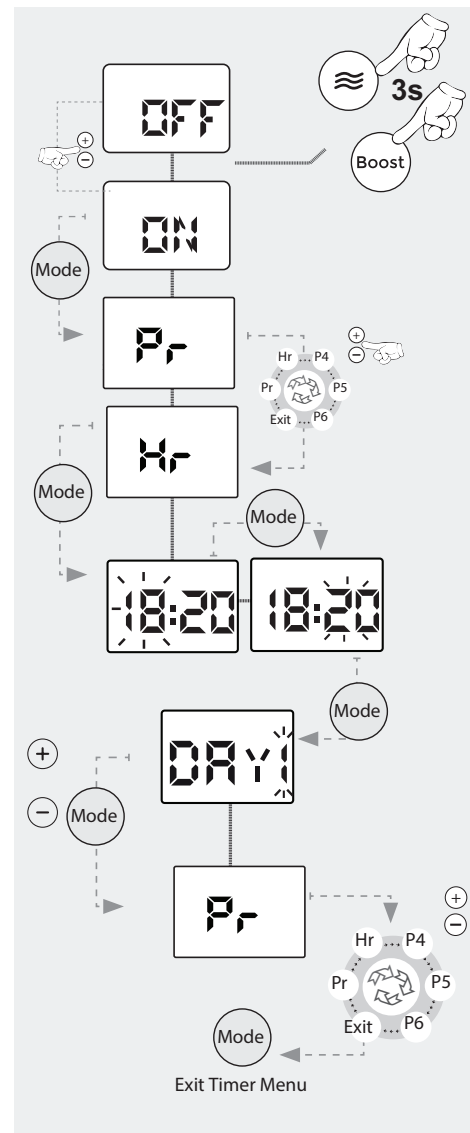

Boost Mode

The Boost function allows you to make temporary adjustments for a more flexible operation. The function allows you to activate the maximum heating power of the device for an adjustable duration. Once the selected duration has elapsed, the Heater will return to the mode that was active before Boost was activated.

Activation and deactivation

Press the 'Boost' button to activate the maximum heating power of the device, adjusting the duration with the 'up' and 'down' buttons (from 5 minutes to 2 hours).

Pressing 'Boost' will end Boost early, restoring the heater back to its previously active mode.

Default duration setting

After launching the "Boost" function with the choice of duration setting, press and hold the 'Mode' button for 3 seconds to save this duration as the default.

Daily Preheat

The Daily Preheat function allows the product to be configured to preheat the rail for 30 minutes prior to a desired time.

Two daily periods may be saved. Each period must be configured at the desired time and will then automatically preheat each day at these times. The daily preheat indicators will be illuminated to indicate that period has been saved.

To setup the daily periods:

Hold the Daily Preheat button for 3 seconds to save the current time as a preheat period.

To view the daily periods:

Press the Daily Preheat button to view the saved periods. The indicator of the selected period will be illuminated and the saved time will be displayed on the screen.

To delete daily periods:

While a saved period is displayed, hold the Daily Preheat button to delete that period.



NOTE:

To ensure safe operation, if the temperature sensor measures a temperature greater than 40C while boost is active, the product will stop heating until the temperature drops below this value.

Product Locks



WARNING:
It is **IMPORTANT** to remember the pin lock code. If you forget, you will no longer be able to unlock the product.

Product Locks are methods of locking the heater's controller to restrict access to functions. When Product Lock is activated, the heater continues to run in whichever mode is currently active.

🔑 A key symbol will be displayed on the top left of the screen when a lock is enabled.

The product can be switched on or off using the power button, and the Boost feature can be activated using the Boost button. The lock must be disabled to modify all other settings.

Key Lock

This is the simplest locking method and does not utilise a PIN code. It is toggled on/off on the heater's controller by pressing and holding the up and down buttons for three seconds.

The product can be switched on or off using the power button. The lock must be disabled to modify all other settings.

Heater Lock (PIN Lock)

Heater Lock is the most customisable and secure lock on the heater. This allows the heater to be configured in any way, then locked into those settings and modes with a 4-digit code.

To lock

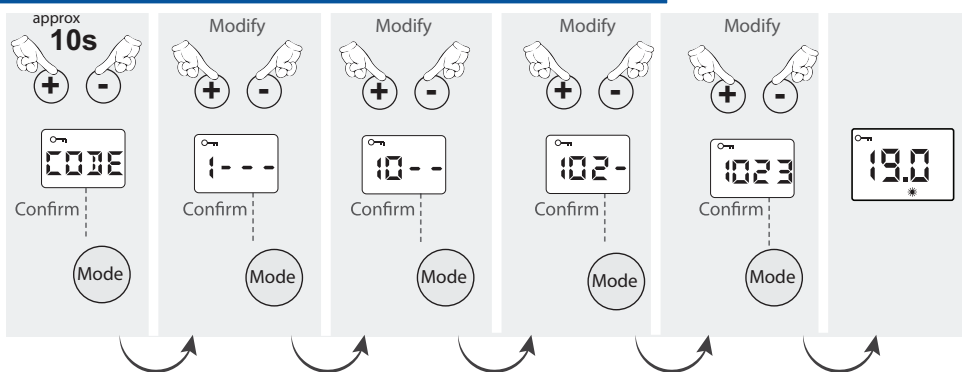

To unlock

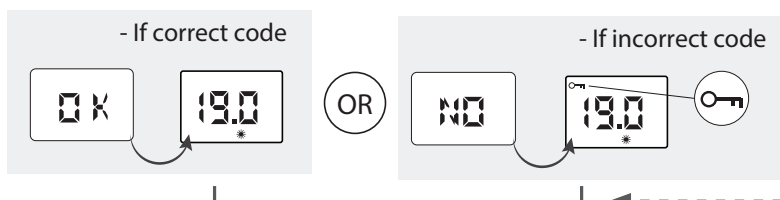
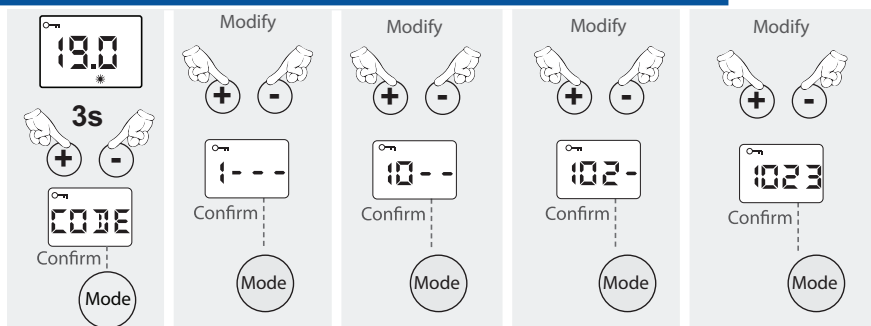

Open Window Detection

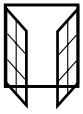

This is a global setting that can interrupt any active mode. Activating this setting enables Open Window Detection to switch the Heater to a 'Heating Off' state if it detects an open window in the room it's operating in.

The open window detection symbol is displayed when open window detection is enabled. This function is enabled by default.

The symbol flashes on the screen when the heating has stopped following detection of an open window and/or door. This function automatically stops heating if a sudden drop in temperature is detected in the room (e.g. an open window or door).

Pressing any button will automatically restart the heating.

To enable or disable the open window function see "Advanced Settings" section.

Avoid installing the device in a draft likely to disrupt its regulation.



NOTE:

In environments where the product may read sudden decreases in temperature, this feature may activate in error. This can occur in drafty or poorly insulated environments as well as if the heater is undersized for the room. This feature should be disabled using the instructions above if activating for reasons other than the intended purpose. If you think that your environment is not as described here and this feature is activating, please contact our customer care team with the details on the rear page of this document.

Temperature Adjustment Limit

When this function is activated, the adjustment of the comfort temperature is limited to $\pm 2^{\circ}\text{C}$ of the comfort temperature at the time of activation.

To enable or disable the temperature adjustment limit function see "Advanced Settings" section.

Advanced Settings

This menu allows you to modify the advanced settings on the products.

To access the advanced settings menu, follow these steps:

Press the power button, the screen displays '- - - -'.

Press Mode and on/off buttons for 3 seconds until the screen displays 'CONF'.

Press for 3 seconds on Preheat gives access to the adjustment of the various parameters (see below).

1. Backlight

The backlight will flash.

Select the required setting (top right corner) using the up or down button.

- 0 = The backlight will remain permanently on,
- 1 = The backlight will turn off after 10 seconds.

Press the mode button to save the setting and progress to the next option.

2. Open Window Detection

The open window detection symbol will be displayed.

Select the required setting (top right corner) using the up or down button.

- 0 = To disable Open Window Detection,
- 1 = To enable Open Window Detection.

Press the mode button to save the setting and progress to the next option.

3. Temperature Unit

The current temperature unit will be displayed.

Select the required unit using the up or down button.

- °C = Degree Celsius will be used as the temperature unit,
- °F = Fahrenheit will be used as the temperature unit.

Press the mode button to save the setting and progress to the next option.

4. Temperature Adjustment Limit

"LIM" will be displayed on the screen.

Select the required setting (top right corner) using the up or down button.

- 0 = To disable the limit function,
- 1 = To enable the limit function.

Press the mode button to exit the advance menu and return to the homescreen.

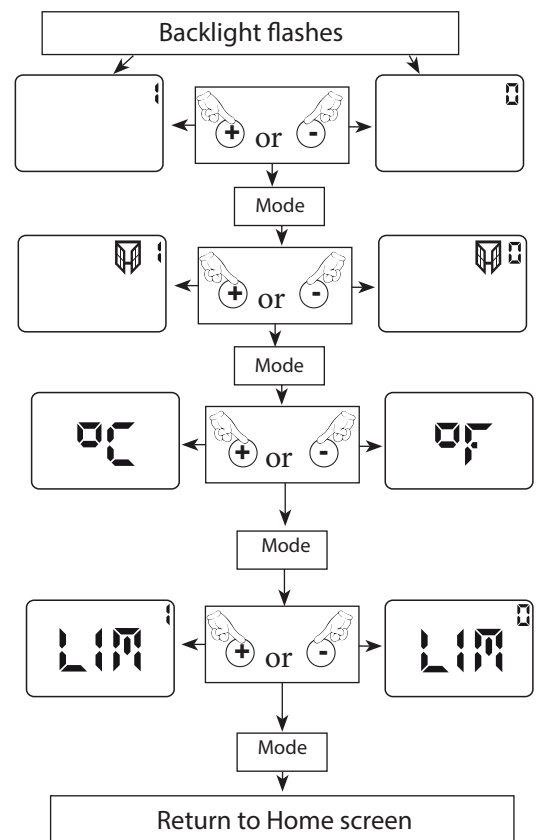

Temperature Calibration

In some circumstances, there may be a gap between the display of the device and that of a thermometer. If this difference is greater than $\pm 0.5^{\circ}\text{C}$, it is possible to calibrate the heater.

Operating mode:

To compare the temperature displayed by the radiator with that indicated by a thermometer, you must:

- ensure that the instructions in the installation instructions, in particular positioning and minimum distances, are respected,
- close all exterior openings of the accommodation as well as the interior door(s) of the room heated by the radiator,
- place your thermometer in the center of the room at a height of approximately 1.2m, do not place it on furniture,
- put the radiator in manual COMFORT mode,
- check that your setpoint is set between 17 and 23°C,
- wait for the thermal stabilization of the room (around 6 hours) and avoid coming and going in the room as much as possible,
- ensure that the temperature displayed on the radiator and that on the thermometer are stable.

This adjustment can only be made if the above conditions are respected.

With the thermostat in COMFORT mode, press MODE for 3 seconds, two cases may arise:

1. The set temperature flashes, calibration is then possible.
 - Display the temperature indicated by your thermometer with the up and down buttons.
 - Save using the MODE button.
2. The display indicates "NO": calibration is not possible (you must then wait for the temperature to stabilise).



NOTE:

If the up and down buttons are not pressed within for 15 seconds, the display returns to the homescreen.

Troubleshooting

Issue	Check	Action
The product is not heating.	Ensure the display is active.	Press the on/off button. Press Mode repeatedly until the Comfort symbol is displayed.
	If the display still is not on.	Ensure the isolation switch is on.
	Ensure comfort mode is active.	Press Mode successively until the Comfort position is displayed.
	Ensure the open window function has not activated and that a window or door is not open in the room.	Close the door and/or window, reset the function, see the "Open Window Detection" section.
	The display is active, the heating indicator is off.	Room temperature does not require heating. Check the set temperature. The product may be in Eco or Frost Protect mode.
The product is constantly heating.	Check that the set temperature is at the desired value.	Adjust the temperature again.
	Check that the appliance is not located near an open door or/or in a	Close the door or remove the draft.
The product is not following the timer schedule.	Check that it is in timer mode.	Put in timer mode.
	Check the timer profiles.	Adjust the daily timer profiles.

If the issue is not resolved, please refer to the support section at the end of this document.

Maintenance

There are no user serviceable parts on the towel rail.

The rail is filled with a precise quantity of special liquid and for electric only operation should never need draining or refilling. Repairs requiring the opening of the liquid-tight seal must only be made by the manufacturer's Service Agent. Any leakage must be reported to the manufacturer's Service Agent.

The controller and cable are a single unit. Any maintenance must be carried out by the manufacturer's Service Agent using the recommended parts.

Cleaning

The finish on your towel rail can be maintained by occasionally wiping over with a damp cloth and lightly finishing with a soft dry cloth. This should only be carried out when the rail is cold. Do not use abrasive cleaning powders as this could damage the surface finish.



WARNING:
Always disconnect from the power supply before cleaning the product.

Your Guarantee



To view the full guarantee terms and conditions scan this QR code using your smartphone or go to <https://www.gdhv.co.uk/guarantee-terms-and-conditions>.

Your Product is manufactured by Glen Dimplex UK operating as Glen Dimplex Heating & Ventilation. GDHV designs and manufactures products to ensure they deliver reliable service for normal use in domestic dwellings and, where specified by us, in light commercial premises.

GDHV products are individually tested before leaving the factory, Your product comes with a 2 year parts and labour guarantee for repair or replacement of faulty goods and/or partial refund in the event that a repair or replacement is not available.

Your guarantee is provided by Glen Dimplex UK Ltd operating as Glen Dimplex Heating & Ventilation Ltd, Millbrook House, Grange Drive, Southampton SO30 2DF. Terms and conditions apply.

The GDHV guarantee does not in any way diminish or affect your statutory consumer rights in connection with your product.



If you experience a problem with your product during or after the guarantee period, visit our online help centre:

support.credaheating.co.uk

Please note for support you will need the model and serial number of your product and a description of the fault which has occurred.



Important: For electrical products sold within the European Community. At the end of the electrical products useful life it should not be disposed of with household waste. Please recycle where facilities exist. Check with a Local Authority or retailer for recycling advice in your country. Batteries should be disposed of or recycled in accordance with WEEE Directive 2012/19/EU. Packaging should be recycled where possible.

Creda

HEATING

www.credaheating.co.uk

Creda Heating
Millbrook House, Grange Drive, Hedge End, Southampton, SO30 2DF



© Glen Dimplex. All rights reserved. Material contained in this publication may not be reproduced in whole or in part, without prior permission in writing of Glen Dimplex.